

Finger jointing lines Ultra / Ultra TT

Finger jointing lines Ultra / Ultra TT

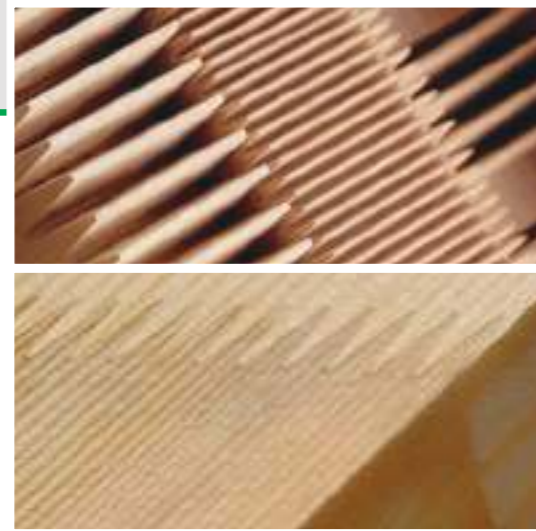

Synoptical table – Standards and options

Your WEINIG GRECON expert will give you detailed information

	Ultra	Ultra TT
Infeed length	150 – 1.000 mm	(150 *) 200 – 1.000 mm **
Timber width	(30 *) 40 – 205 (225 *) mm	(30 *) 40 – 205 (225 *) mm
Timber thickness	(16 *) 20 – 80 (100 *) mm	(16 *) 20 – 80 (100 *) mm
Outfeed length	3.000 – 6.100 mm **	3.000 – 6.100 mm **
Thrust force	120kN/12t (145kN/14,5t *)	120kN/12t (145kN/14,5t *)
Timber cross section – finger length 10/11 mm (softwood)	100 cm ² (120 cm ² *)	100 cm ² (120 cm ² *)
Timber cross section – finger length 10/11 mm (hardwood)	80 cm ² (96 cm ² *)	80 cm ² (96 cm ² *)
Capacity (vertical jointing) with 30 x 90 x 400 mm	15,2 m/min	19,3 – 22,4 m/min
Capacity (horizontal jointing) with 22 x 50 x 350 mm	7,3 m/min	11,7 m/min
Shaper types	manual turntable shaper	automatic turntable shaper
Transfer station	semi-automatic/automatic	semi-automatic/automatic
Press	two-channel press	two-channel press
Production statistics	●	●
Diagnosis system	○	○
Multiple lengths	○	○
Intermediate cuts	○	○
Scoring units (top and bottom)	○	○
Timber thickness min. 16 mm	○	○
Timber thickness max. 100 mm	○	○
Timber width min. 30 mm	○	○
Shuffling limit stop	○	●
Timber monitoring	○	●
Splinter protection	●	●
Glue application system Flankenjet	●	●
Communication (Teleservice)	○	○
Capacity reserve, cutter spindle drive	○	○
Frequency controlled shaper table	●	●
Servo-controlled shaper table	○	○

* Optionally ** Longer lengths on request

Technical modifications reserved. Information and figures in this brochure also include special equipment which is not part of the standard scope of supply. Protection covers partially removed for the photos.

● Standard ○ Option

High performance for horizontal and vertical joints

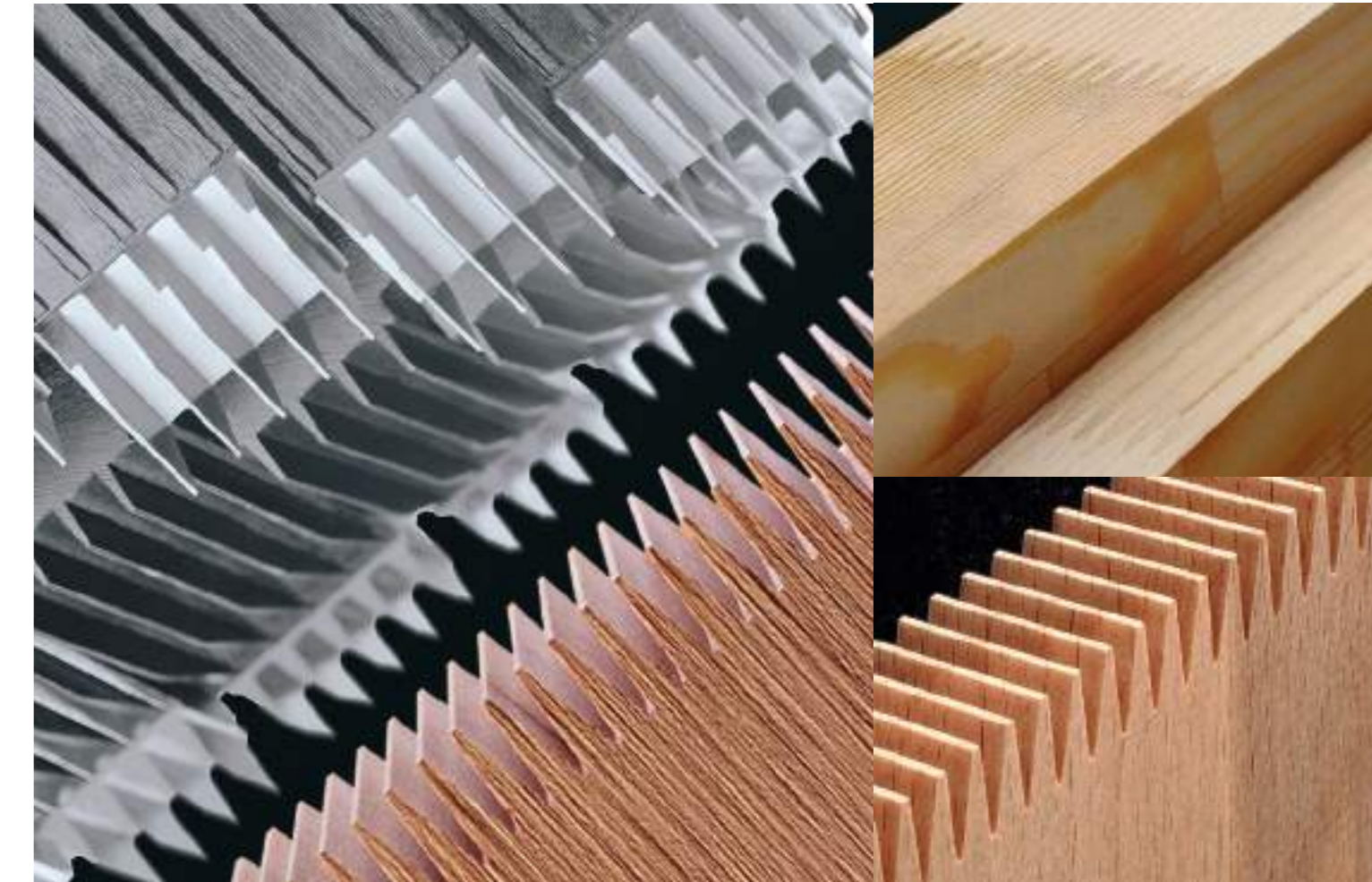

Product Unit Jointing Technology

WEINIG GRECON GMBH & CO. KG

Hannoversche Str. 58
31061 Alfeld / Hannover
Germany

Phone +49 (0) 51 81 / 939-0
Fax +49 (0) 51 81 / 939-225
E-Mail info-jointing@weinig.com
Internet www.weinig.com



WEINIG GRECON finger jointing lines of the series Ultra – State-of-the-art technology for highest demands

The compact finger jointing lines of the series Ultra are a perfect solution for the economic timber enhancement and the manufacture of homogenous solid wood products. We have designed these systems especially for the appropriate capacity need, average quantities of short lengths without deviating from the high WEINIG GRECON quality standards of our “top class”.

The front ends of the timber pieces are first aligned and afterwards rectangularly cut on the finger jointing package shaper with a width of 600 mm and a height of max. 205 (225 *) mm. By means of the optimised shaping unit, the profile of the finger joints is cut into the face of the timber piece package. After rotating the package on the turntable, the second face is moved to the shaper. The cutter spindle is automatically shifted by half a finger to ensure a precise joint without offset. Following the second cutting process, the exactly dosed glue quantity is applied by the patented Flankenjet system. The profiled and glued timber pieces are fed into the hydraulic press with integrated saw, cut to length and pressed. Top and bottom scoring units can be used as option making the optimal edge cutting possible together with the lifting spindle (furniture and parquet quality). The performance can be increased by approx. 40 % with the line type Ultra TT (automatic servo-turntable) or infeed lengths of up to 1.5 m can be processed.



The Ultra TT –

- Compact system with state-of-the-art technology and clear process.
- The system is especially characterised by its capacity, the high speed and the top quality of the joints.
- High production performance thanks to the fully automatic passage through the system (optionally).



Compact high performance technology

WEINIG GRECON is the leading manufacturer of innovative finger jointing lines. The systems of type Ultra are our response to the high quality demands of the timber industry.



Options for a better performance

Ultra / Ultra TT with semi-automatic infeed device for the separation of up to 60 pieces / min.

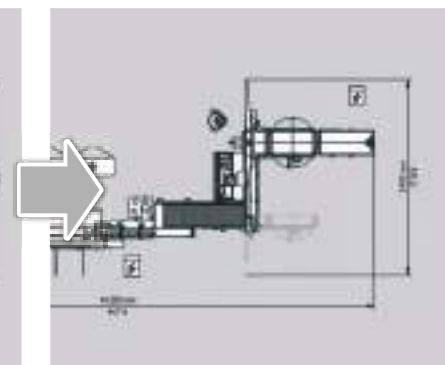
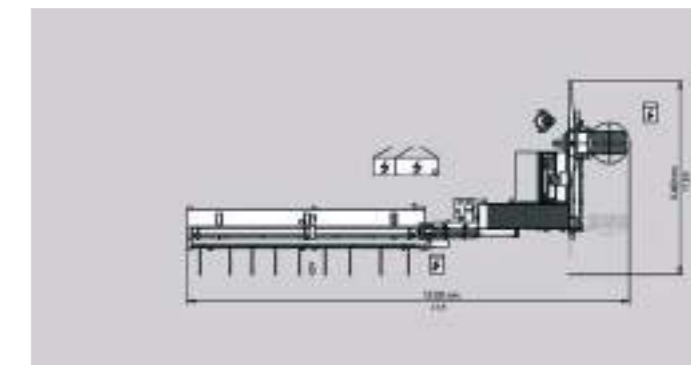

Ultra / Ultra TT Comfort with semi-automatic transfer station for the separation of up to 80 pieces / min, automatic length measurement.

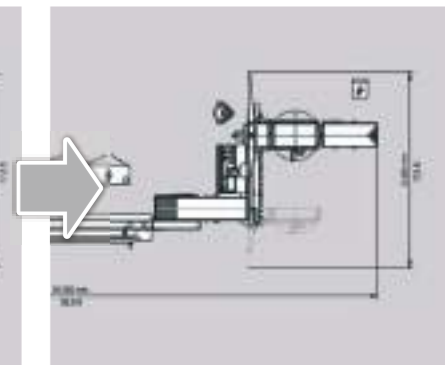
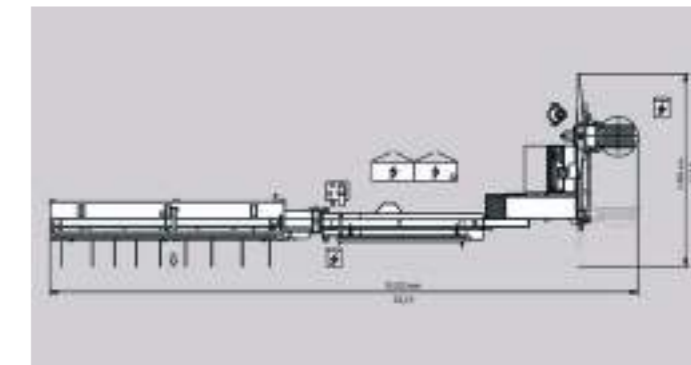

Ultra / Ultra TT Capacity with automatic transfer station for the separation of up to 100 pieces / min, and automatic length measurement.

